

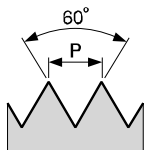

## Метчици ръчни, комплект 3 броя, DIN 352, HSS

### Метрична резба М

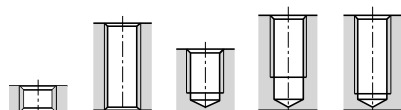
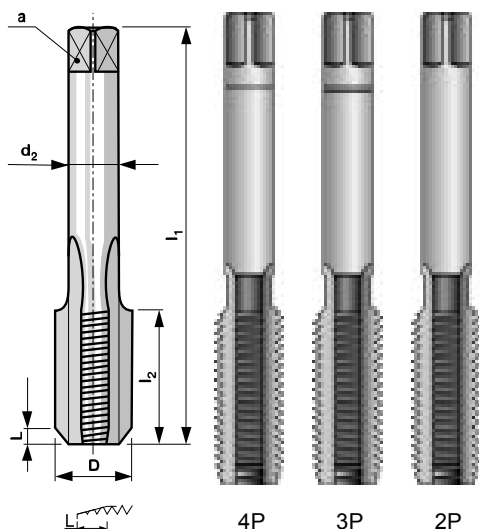

D	P	l <sub>1</sub>	l <sub>2</sub>	d <sub>2</sub>	a	препоръчителен размер на свредлото, mm	Z брой пера
M 2	0,4	36	8	2,8	2,1	1,60	3
M 2,2	0,45	36	9	2,8	2,1	1,75	3
M 2,5	0,45	40	9	2,8	2,1	2,05	3
M 3	0,5	40	11	3,5	2,7	2,50	3
M 3,5	0,6	45	13	4	3	2,9	3
M 4	0,7	45	13	4,5	3,4	3,3	3
M 4,5	0,75	50	16	6	4,9	4,0	3
M 5	0,8	50	16	6	4,9	4,2	3
M 6	1	50	19	6	4,9	5,0	3
M 7	1	50	19	6	4,9	6,0	3
M 8	1,25	56	22	6	4,9	6,8	3
M 9	1,25	63	22	7	5,5	7,8	3
M 10	1,5	70	24	7	5,5	8,5	3
M 11	1,5	70	24	8	6,2	9,5	3
M 12	1,75	75	29	9	7	10,2	3
M 14	2	80	30	11	9	12,0	3
M 16	2	80	32	12	9	14,0	3
M 18	2,5	95	40	14	11	15,5	3
M 20	2,5	95	40	16	12	17,5	3
M 22	2,5	100	40	18	14,5	19,5	3
M 24	3	110	50	18	14,5	21,0	3
M 27	3	110	50	20	16	24	3
M 30	3,5	125	56	22	18	26,5	3